

MICROMODULE MOTOR CONTROLLER

QUICK INSTALLATION GUIDE
v1.4

TRADEMARKS

Zipato and the Zipato logo are registered Trademarks. All other product names mentioned herein may be trademarks or registered trademarks of their respective companies.

NOTICE

Although Zipato has attempted to ensure the accuracy of the content of this manual, it is possible that this document may contain technical inaccuracies, typographical, or other errors. Zipato assumes no liability for any error in this publication, and for damages, whether direct, indirect, incidental, and consequential or otherwise, that may result from such error, including, but not limited to loss of data or profits. Zipato provides this publication "as is" without warranty of any kind, either express or implied, including, but not limited to implied warranties of merchantability or fitness for a particular purpose. The published information in the manual is subject to change without notice. Zipato reserves the right to make changes in the product design, layout, and driver revisions without notification to its users. This version of the Installation guide supersedes all previous versions.

ELECTROMAGNETIC COMPATIBILITY

When operated according to manufacturer instructions, the product complies with all applicable CE harmonised standards from EMC Directive 2004/108/EC and Part 15 of the FCC Rules. The connections conducting HF signals must not be damaged or altered in any way by the user.

TAKE CARE OF YOUR SAFETY

Display extreme caution when using ladders or steps, please follow manufacturer's instructions. Be careful when using hand and power tools and follow the manufacturer's guidelines when using them. Take care that the correct tools are used. Wear goggles or protective clothing where required.

DANGER

RISK OF ELECTROCUTION

All work on the device should only be carried out by trained and skilled electricians. Observe the country-specific regulations.

DANGER

RISK OF FATAL INJURY FROM ELECTRIC CURRENT.

The device has no basic insulation and must therefore be installed in a way that protects against accidental contact.

DANGER

RISK OF FATAL INJURY FROM ELECTRIC CURRENT.

When installing a wall plate, the distance between the cover's fixing brackets or screws and the connections of the flush-mounted MicroModule Motor Controller must be at least 4 mm once installed. If the distance is less than 4 mm, a deeper installation box must be used. The fixing brackets or screws of the cover must not press against the housing. Only insulated tools may be used for operation on the device, e.g. an insulated phase tester.

CAUTION

The connected devices and the flush-mounted receiver can become damaged if devices are operated that do not correspond to the technical specifications (see technical data).

INTRODUCTION

Using Micromodule Motor Controller user can control connected roller shutters and blinds, finely adjust their position with his Z-Wave controller, Z-Wave remote or simple push of a button.

Micromodule Motor Controller is Z-Wave Plus enabled device which makes it compatible with any Z-Wave enabled network, regardless of the manufacturer. Slim design makes it easy to fit in majority of wall boxes. New smart-relay calibration technology reduces inrush current caused by the load and enables module to work perfectly with all kinds of roller shutters and blinds.

Micromodule is able to detect position of the Shutter by using the patterned power measuring method, so it can be remote controlled not only fully up or down, but also can be adjusted to ex. 30% or 50%. When manually operated by the push button, Micromodule Motor Controller can also memorize the position and send the new shutter position to its controller (ex. IP-Gateway).

OVERVIEW

FIGURE 1
Dimensions [unit: mm]

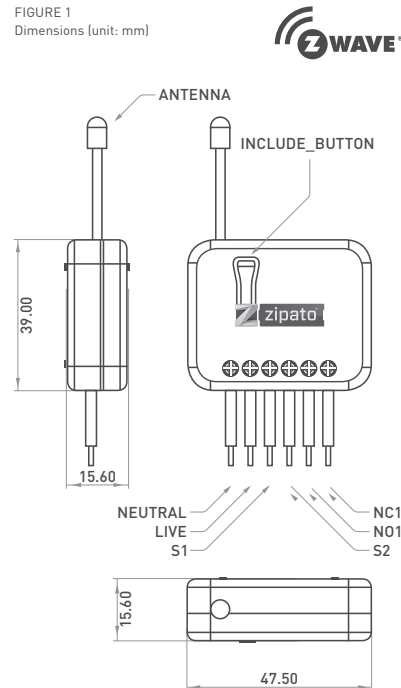

PACKAGE CONTENT

1PC	Micromodule Motor Controller
1PC	Quick Installation Guide

FEATURES

- Slim, compact remote Z-Wave module switches and controls all parameters of power that your electrical appliances consume.
- Precise feedback about roller position
- Max load up to 1100W
- Zero-crossing switch
- Higher output power enhances communication range(+2.5dBm output power compared to -2.5dBm 300 series)
- New Z-Wave 500 series chip supports multichannel operation and higher data rates (9.6/40/100kbps)
- Overload protection
- Auto reports wattage when variation exceeds 5%
- Very low power consumption
- Over-the-air firmware update
- Easy installation

SPECIFICATION

TECHNICAL SPECIFICATION

PROTOCOL	Z-Wave Plus
OPERATING VOLTAGE:	100-240VAC
MAXIMUM LOAD	5A (Resistive load)
OPERATING TEMPERATURE	0°C - 40°C
RANGE	Minimum 30m indoor / 70m outdoor
WEIGHT	39g
DIMENSIONS	46mm x 15mm x 39mm
PACKAGE WEIGHT	68g
PACKAGE DIMENSIONS	67mm x 22mm x 162mm
REGULATIONS	EMC 2004/108/EC, R&TTE 1995/5/EC, LVD 2006/95/EC, FCC PART 15
WARRANTY	1 year

MODELS AND FREQUENCIES

EUROPEAN UNION - EU version	ph-pan08.eu / 868.42 MHz
UNITED STATES - US version	ph-pan08.us / 908.42MHz
RUSSIA - RU version	ph-pan08.ru / 869.02MHz
ISRAEL - IS version	ph-pan08.is / 916.02MHz
AUSTRALIA - AU version	ph-pan08.au / 921.42MHz
INDIA - IN version	ph-pan08.in / 865.20MHz

INSTALLATION AND OPERATION

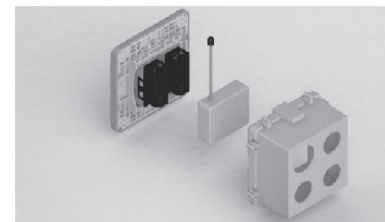

- Put the in wall Micromodule into a wall box and connect the AC power wire L,N to Micromodule connector L, N.
- Connect the wall switch to the Micromodule as shown in picture
- To manually roll the shutter/blinds up or down, simply press the external switch S1 or S2. The detail is described in Z-Wave configuration section (External switch type) of this manual.
- Micromodule built in meter function can read the Watt, kWh, V(Voltage), I(Current), PFI(Power Factor) of the load by using Z-Wave command class, user can set a threshold current to get the warning caused by abnormal operation.
- Micromodule have overload protection function, and can help to prevent short circuit caused by load.

APPLICATION

- In Wall Switch 2 relay; 1A and 1C Type

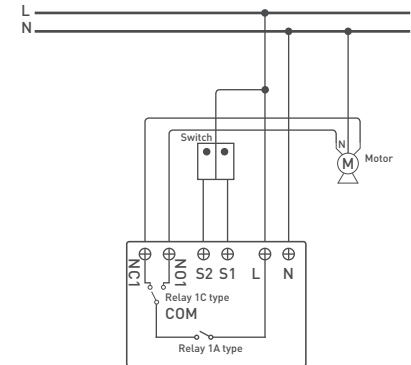

CHOOSING A SUITABLE LOCATION

- Do not locate the Micromodule facing direct sunlight, humid or dusty place.
- The suitable ambient temperature is 0°C-40°C.
- Do not locate the Micromodule where there are any combustible substances or sources of heat, e.g. fires, radiators, boiler etc.
- After putting it into use, the body of Micromodule may become little hot on touch, which is normal operation.

MOVING RANGE CALIBRATION

- It is important to carry out a shutter calibration process before putting controller to use with your shutters. Press and hold inclusion button for more than 3 seconds and release before the 6th second, after which Micromodule will start shutter calibration process. The process is composed of three consecutive stages. The shutter moves to the TOP in first stage, and to the BOTTOM in second stage, and to the TOP again in third stage. After calibration procedure, Micromodule will correctly memorize full range of UP and DOWN shutter movement.
- During the shutter calibration process, if any emergency happens you can press and release the include button to stop the process.
- If shutter movement direction is reversed, this may be caused by the wrong connection of NC and NO to the motor, please change NC and NO connection and execute calibration process again.
- For safe issue, please select the motor which can stop by itself when going to bottom end or top end.

LED INDICATION

State Type	LED Indication
Motor activate	Regardless of up and down position, or open/closed status, Led will flash every second during Motor activate state. When S1 or S2 close to L, the LED will flash even when the motor stop by itself, this is to let user know the S1 or S2 are still closed and not being released yet
No node ID	Under normal operation, when the Micromodule has not been allocated a node ID, the LED flashes on and off alternately at 2-second intervals. By pressing S1, S2 or Include button, it will stop flashing temporarily.
Learning	When Micromodule is in learning mode, LED flashes on and off alternately and repeatedly at 0.5 second intervals.
Overload	When overload state occurs, the Micromodule is disabled and LED flashes on and off alternately at 0.2 second intervals. Micromodule will send alarm_type=8 alarm_Level=0xFF to Group1. Overload state can be cleared by disconnecting and reconnecting the Micromodule to the main power.

ADDING TO Z-WAVE NETWORK

In the front casing, there is an include button with LED indicator below which is used to carry out inclusion, exclusion, reset or association. When first power is applied, LED repeatedly flashes in 0.5 second intervals. It implies that it has not been assigned a node ID and start auto inclusion.

➔ AUTO INCLUSION

The function of auto inclusion will be executed as long as the Micromodule does not have Node ID and is connected to main power.

Note: Auto inclusion timeout lasts 2 minutes during which the node information of explorer frame will be emitted once every several seconds. Unlike "inclusion" function as shown in the table below, auto inclusion doesn't require pressing on/off buttons on the Micromodule. The table below lists an operation summary of basic Z-Wave functions. Please refer to the instructions for your Z-Wave Certificated Primary Controller to access the Setup function, and to include/exclude/associate devices.

Function	Description	LED Indication
No node ID	The Z-Wave Controller does not allocate a node ID to the Micromodule.	2-second on, 2-second off
Inclusion	Put your Z-Wave controller into inclusion mode by following the instructions provided by the controller manufacturer.	One press one flash
	Pressing Include button three times within 2 seconds will enter inclusion mode.	
Exclusion	Put the Z-Wave Controller in exclusion mode.	One press one flash
	Pressing Include button three times within 2 seconds will enter exclusion mode.	
Reset	Node ID has been excluded.	0.5-second on, 0.5-second off
	Pressing Include button three times within 2 seconds will enter inclusion mode.	One press one flash
	Within 1 second, press Include button again for 5 seconds until LED is off.	
Association	IDs are excluded.	0.5-second on, 0.5-second off
	Have Z-Wave Controller entered in association mode. OR Pressing Include button three times within 2 seconds will enter association mode.	One press one flash
	There is 1 group [Group 1] for the Micromodule	
	Including a node ID allocated by Z-Wave Controller means inclusion. Excluding a node ID allocated by Z-Wave Controller means exclusion. Failed or success in including/excluding the node ID can be viewed from the Z-Wave Controller.	

PROGRAMMING

1 | BASIC COMMAND CLASS

The Micromodule will respond to BASIC and BINARY commands that are part of the Z-Wave system.

1.1 | BASIC_GET

When Micromodule receives Basic Get Command it will send Basic Report Command to report the position of the shutter. When the

report value is 0x00, that mean the shutter is at the Bottom, if the report value is 0x63 or 0xFF that mean the shutter is at the Top, any other value between 0x01-0x62 imply shutter is at the position between top and bottom.

Basic Get Command: [Command Class Basic, Basic Get]

Basic Report Command:
[Command Class Basic, Basic Report, Value = 0x00 [BOTTOM]]
[Command Class Basic, Basic Report, Value = 0x01-0x62 [Between BOTTOM and TOP]]
[Command Class Basic, Basic Report, Value = 0x63/0xFF [TOP]]

1.2 | BASIC_SET

Micromodule can accept Basic Set Command which value is either [0x00]Bottom or Top [0x63/0xFF] or [0x01-0x62] the position between TOP and Bottom. Other value [0x64-0xFE] is not acceptable.

[Command Class Basic, Basic Set, Value = 0x63 or 0xFF] control the shutter to the top [0xFF]

[Command Class Basic, Basic Set, Value = 0x00[0]] control the shutter to the bottom[0x00]

[Command Class Basic, Basic Set, Value = 0x01-0x62] control the shutter to the position between bottom and top

2 | BINARY SWITCH COMMAND CLASS

2.1 | BINARY_SWITCH_GET

When Micromodule receives Binary Switch Get Command, it will send Binary Switch Report Command to report the position of the shutter. When the report value is 0x00, that means the Shutter is bottom down, if the report value is 0xFF that mean the Shutter is at the top. But if report value is 0xFE that means the position is unknown.

Binary Switch Get Command:
[Command Class Binary Switch, Binary Switch Get]
Binary Switch Report Command:
[Command Class Binary Switch, Binary Switch Report, Value = 0x00[BOTTOM]]
[Command Class Binary Switch, Binary Switch Report, Value = 0xFE[UNKNOWN]]
[Command Class Binary Switch, Binary Switch Report, Value = 0xFF[TOP]]

2.2 | BINARY_SWITCH_SET

Micromodule can only accept Binary Switch Set Command which value is either [0x00] Bottom or Top [0xFF], other value is not acceptable.

[Command Class Binary Switch, Binary Switch Set, Value = 0xFF[255]] control the shutter to the top [0xFF]. But if the shutter is on the way down, this command will stop the shutter.
[Command Class Binary Switch, Binary Switch Set, Value = 0x00[0]] control the shutter to the bottom[0x00]. But if the shutter is on the way up, this command will stop the shutter.

3 | MULTILEVEL SWITCH COMMAND CLASS (VERSION 3)

3.1 | MULTILEVEL_SWITCH_SET

Micromodule can accept Multilevel Switch Set Command which value is either [0x00] Bottom or Top [0x63 or 0xFF] or [0x01-0x62] the position between TOP and Bottom. Other value [0x64-0xFE] is not acceptable.

[Command Class Multilevel Switch, Multilevel Switch Set, Value = 0x63 or 0xFF[255]] control the shutter to the top [0xFF]

[Command Class Multilevel Switch, Multilevel Switch Set, Value = 0x00[0]] control the shutter to the bottom[0x00]

[Command Class Multilevel Switch, Multilevel Switch Set, Value = 0x01-0x62] control the shutter to the position between Bottom and Top.

3.2 | MULTILEVEL_SWITCH_GET

When Micromodule receives Multilevel Switch Get Command, it will

send Multilevel Switch Report Command to report the position of the shutter. When the report value is 0x00, that mean the shutter is at the Bottom, if the report value is 0x63 or 0xFF that means the shutter is at the top, any other value between 0x01-0x62 imply shutter is at the position between top and bottom.

Switch Multilevel Get Command:
[Command Class Multilevel Switch, Multilevel Switch Get]

Multilevel Switch Report Command:
[Command Class Multilevel Switch, Multilevel Switch Report, Value = 0x00[BOTTOM]]
[Command Class Multilevel Switch, Multilevel Switch Report, Value = 0x01-0x62[Between BOTTOM and TOP]]
[Command Class Multilevel Switch, Multilevel Switch Report, Value = 0x63/0xFF[TOP]]

3.3 | MULTILEVEL_SWITCH_START_LEVEL_CHANGE

This is the command which is used to move the shutter up to the top or down to the bottom.

[Command Class Multilevel Switch, Multilevel Switch Start Level Change, Up/Down Value]

3.3.1 | UP/DOWN BIT:

If Up/Down Bit=0x00 Shutter move up
If Up/Down Bit=0x01 Shutter move down
If Up/Down Bit=0x03 no move

[Command Class Multilevel Switch, Multilevel Switch Start Level Change, Up/Down=0x00] control the shutter to the top [0xFF]

[Command Class Multilevel Switch, Multilevel Switch Start Level Change, Up/Down=0x01] control the shutter to the bottom [0x00]

[Command Class Multilevel Switch, Multilevel Switch Start Level Change, Up/Down=0x03] Don't move the shutter or stop the moving shutter

- ATT. ■ Ignore_Start_Level, Start_Level, Dimming_Duration, Inc/Dec, Step_size can not be used.
- Micromodule can not control the speed of motor.
- It may have some distance error caused by motor start up time.
- If user finds the error become significant, you may use S1 or S2 to move the shutter to the end or remotely move shutter to 0% and 100%, which will automatically calibrate this error.

3.4 | MULTILEVEL_SWITCH_STOP_LEVEL_CHANGE

When receives Multilevel Switch Stop Level change Command Micromodule will stop the motor.

4 | SCENE ACTIVATION COMMAND CLASS

4.1 | SCENE_ACTIVATION_SET_COMMAND

When Micromodule receives Scene Activation Set command, it will read the level of the pre-configured Scene ID from EEPROM. And it will be controlled as a Multilevel Switch Set command. The Dimming Duration of the command will be ignored because Micromodule can not control the speed of motor.

5 | SCENE ACTUATOR CONFIGURATION COMMAND CLASS

5.1 | SCENE_ACTUATOR_CONFIGURATION_SET_COMMAND

[Command Class Scene Actuator Configuration, Scene Actuator Configuration Set, Scene ID=1-255, Override bit=0, Level=0-99 or 255] The current setting of MM Motor Controller will not be override.

[Command Class Scene Actuator Configuration, Scene Actuator Configuration Set, Scene ID=1-255, Override bit=1, Level=0-99 or 255] The Level value in this Command is associated to the Scene ID.

5.2 | SCENE ACTUATOR CONFIGURATION GET COMMAND

[Command Class Scene Actuator Configuration, Scene Actuator Configuration Get, Scene ID=1-255]

[Command Class Scene Actuator Configuration, Scene Actuator Configuration Report, Scene ID=1-255, Level=0-99 or 255, Dimming Duration=0-0xFE] Report the Pre-configured Scene ID of MM Motor Controller.

6 | Z-WAVE'S GROUPS INTRODUCTION (ASSOCIATION COMMAND CLASS VERSION 2)

There is only one group called Group1, there is only one node for Group1 which support MULTILEVEL_SWITCH_REPORT, METER_REPORT_COMMAND_V3, ALARM_REPORT

6.1 | REPORT THE SHUTTER POSITION

Every time when user presses S1 or S2 and let shutter to move, Micromodule will report the position status to controller, and after every 10% movement Micromodule will send Multilevel Switch Report to Group 1 as well.

Multilevel Switch Report: Ex. Report position at 30% [Command Class Multilevel Switch, Multilevel Switch Report, Value = 30[%]]

6.2 | METER COMMAND CLASS

The Switch will report its (1) instant Power Consumption [Watt] or (2) accumulated power consumption[KWH] or (3) AC load Voltage [V] or (4) AC load current [I] (5) load power factor [PF] to Z-Wave Controller after receive the Meter Get Command from Z-Wave Controller. When the power consumption of load vary over 5%, it will send Meter report to the nodes of Group as well.

6.2.1 | INSTANT POWER CONSUMPTION (WATT) OF SWITCH

When receiving Meter Get Command, it will report Meter Report Command to the requested node.

Meter Get Command: [Command Class Meter, Meter Get, Scale=0x02[W]]

Meter Report Command: [Command Class Meter, Meter Report, Rate Type = 0x01, Meter Type = 0x01, Precision = 1, Scale = 0x02, Size = 4, Meter Value[W]]

Example:

Meter Value 1 = 0x00 [W]
Meter Value 2 = 0x00 [W]
Meter Value 3 = 0x03 [W]
Meter Value 4 = 0xEA [W]
Meter[W] = Meter Value 3 *256 + Meter Value 4 = 100.2W

6.2.2 | ACCUMULATED POWER CONSUMPTION (KW/H)

When receiving Meter Get Command, it will report Meter Report Command to the requested node.

Meter Get Command: [Command Class Meter, Meter Get, Scale = 0x00]

Meter Report Command: [Command Class Meter, Meter Report, Rate Type = 0x01, Meter Type=0x01, Precision = 2, Scale = 0x00, Size = 4, Meter Value [KWh]]

Example:

Scale = 0x00 [KWh]
Precision = 2
Size = 4 Bytes [KWh/h]
Meter Value 1 = 0x00[KWh]
Meter Value 2 = 0x01[KWh]
Meter Value 3 = 0x38[KWh]
Meter Value 4 = 0xA3[KWh].

Accumulated power consumption [KW/h] = (Meter Value 2*65536) + (Meter Value 3*256) + (Meter Value 4) = 800.35 KW/h)

6.2.3 | AC LOAD VOLTAGE [V]

When receiving Meter Get Command, it will report Meter Report Command to the requested node.

Meter Get Command: [Command Class Meter, Meter Get, Scale =0x04[V]]

Meter Report Command:
Command Class Meter, Meter Report, Rate Type = 0x01,
Meter Type = 0x01, Precision = 1, Scale = 0x04, Size = 2, Meter
Value[V]]

Example:

Scale = 0x04 [V]
Precision = 1
Size = 2 [2 Bytes of V]
Meter Value 1 = 0x09[V]
Meter Value 2 = 0x01[V]
AC load Voltage = [Meter Value
1*256] +(Meter Value 2)= 230.5 [V]

6.2.4 | AC LOAD CURRENT [I]

When receiving Meter Get Command, it will report Meter Report Command to the requested node.

Meter Get Command: [Command Class Meter, Meter Get, Scale =0x05[I]]

Meter Report Command:
[Command Class Meter, Meter Report, Rate Type = 0x01,
Meter Type = 0x01, Precision = 2, Scale = 0x05, Size = 2, Meter
Value[I]]

Example:

Scale = 0x05 [I]
Precision = 2
Size = 2 [2 Bytes of I]
Meter Value 1 = 0x01[I]
Meter Value 2 = 0x21[I]
AC load current = [Meter Value 1*256] +(Meter Value 2)= 2.89 [A]

6.2.5 | LOAD POWER FACTOR (PF)

When receiving Meter Get Command, it will report Meter Report Command to the requested node.

Meter Get Command: [Command Class Meter, Meter Get, Scale =0x06[PF]]

Meter Report Command:
[Command Class Meter, Meter Report, Rate Type = 0x01, Meter
Type = 0x01, Precision = 2, Scale = 0x06, Size = 1 Bytes, Meter
Value[PF]]

Example:

Scale = 0x06 [PF]
Precision = 2
Size = 1 [1 Byte of PF]
Meter Value 1 = 0x63[PF]
Load power factor [PF] = Meter Value 1 = 0.99

6.2.6 | Reset Accumulated Power Consumption [KWh]

This command is to reset the Accumulated Power Consumption [KWh] to 0 Meter Reset Command.

Meter Reset Command: [Command Class Meter, Meter Reset]

6.3 | ALARM REPORT COMMAND

When Micromodule detects Overload, it will send Alarm_Report to Group1, Alarm Type = 0x08, Alarm Level=0xFF. When receive Alarm_Get command and the Micromodule is not in overload status , it will send Alarm_Report, Alarm Type = 0x08, Alarm Level=0x00.

6.3.1 | ALARM REPORT

When in Two Push Button switch type, S1 or S2 close to L and not been release, and Micromodule receive some control moving command from Z-Wave RF [Ex. BASIC_SET, BINARY_SWITCH_SET, MULTILEVEL_SWITCH_SET, MULTILEVEL_SWITCH_START_LEVEL_CHANGE or MULTILEVEL_SWITCH_STOP_LEVEL_CHANGE or SCENE_ACTIVATION_SET], Micromodule won't do any movement change but report alarm to Group1 that indicate the S1 or S2 not been released. When Micromodule detects a overload power, it will report alarm to Group1.

[Command_Class_Alarm, Alarm_Report, Alarm Type = 0x08,
Alarm Level = 0xFF [Overload]]

[Command_Class_Alarm, Alarm_Report, Alarm Type = 0x08,
Alarm Level = 0x00 [Normal]]

When in Two Push Button switch type, S1 or S2 are closed and not released to open, and Micromodule receive any control moving command from Z-Wave RF, it will report alarm to Group1.

[Command_Class_Alarm, Alarm_Report, Alarm Type = 0x01,
Alarm Level = 0xFF [S1 or S2 close to L]]

[Command_Class_Alarm, Alarm_Report, Alarm Type = 0x01,
Alarm Level = 0x00 [S1 and S2 released from L]]

7 | Z-WAVE'S CONFIGURATION

Configuration Parameter 1		
Function	Size (byte)	Value
Watt Meter Report Period	2	0x01-0x7FFF
Unit	Default	Description
5s	720	5*720s=3600s=1 hour

Configuration Parameter 2		
Function	Size (byte)	Value
KWH Meter Report Period	2	0x01-0x7FFF
Unit	Default	Description
10min	6	6*10min= 1 hour

Configuration Parameter 3		
Function	Size (byte)	Value
Threshold of current for Load Caution	2	10-500
Unit	Default	Description
0.01 A	500	500*0.01=5 A

Configuration Parameter 4		
Function	Size (byte)	Value
Threshold of KWH for Load Caution	2	1-10000
Unit	Default	Description
1KWh	10000	

Configuration Parameter 5		
Function	Size (byte)	Value
External switch type	1	1-2
Unit	Default	Description
	2	1: One Push button 2: Two Push button

Configuration Parameter 6		
Function	Size (byte)	Value
Level report mode	1	1-2
Unit	Default	Description
	2	1:Report destination level in 5s 2:Report 10 percent level while running

7.1 | WATT METER REPORT PERIOD

If the setting is configured for 1hour [set value =720], the Micromodule will report its instant power consumption every 1 hour to the node of corresponding Group. The maximum interval to report its instant power consumption is 45 hours [5s*32767/3600=45hr]. Default value is 1 hour.

7.2 | KWH METER REPORT PERIOD

If the setting is configured for 1hour [set value =6], the Micromodule will report its Accumulated Power Consumption [KW/h] every 1 hour to the node of corresponding Group. The maximum interval to report its Accumulated Power Consumption [KW/h] is 227.55 days [10min*32767/1440=227.55 days]. Default value=1 hour.

7.3 | THRESHOLD OF CURRENT FOR LOAD CAUTION

This is a warning when the wattage of load exceeds the preset threshold value, If the setting value is 500, when the load current over this value, Micromodule will send current meter report command to the node of corresponding Group. Default value=500.

7.4 | THRESHOLD OF KWH FOR LOAD CAUTION

This is a warning when the KWh of load over the preset threshold value, If the setting value is 10000, when the Accumulated Power Consumption of Relay1 or Relay2 over this value, Micromodule will send KWh Meter Report command to the node of corresponding Group, minimum value is 1KWh and default value is 10000 kWh.

7.5 | EXTERNAL SWITCH TYPE

7.5.1 | ONE PUSH BUTTON:

When the configuration setting is One Push Button, only S1 input will be valid. The control moving commands can be accepted in this switch type while the shutter is moving. In this switch type, the inclusion/exclusion/reset/association function can also be fulfilled by pressing S1 just like the operation of include button.

When S1 is short pressed, the shutter will move up toward TOP[0xFF]. If during this movement S1 is short pressed again, the shutter will stop moving. A third short pressing of S1 will move the shutter down toward BOTTOM[0x00]. If during this movement S1 is short pressed again, the shutter will stop moving. And so on... Inverting direction and stopping.

7.5.2 | TWO PUSH BUTTON: (THE DEFAULT SETTING IS TWO PUSH BUTTON [2])

If this setting is configured as Two Push Button, S1 and S2 input will be valid, but will not accept pressing S1 and S2 at the same time. In this switch type, the inclusion/exclusion/reset/association function can also be fulfilled by pressing S1 or S2 just like the operation of include button.

When S1 is pressed and held more than 1.5 seconds, the shutter will move up toward TOP[0xFF], and the shutter will stop moving when S1 is released. When S2 is pressed and held for more than 1.5 seconds, the shutter will move down toward BOTTOM[0x00], and the shutter will stop moving when S2 is released.

When S1 is short pressed, the shutter will move up toward TOP[0xFF]. If during this movement S1 is short pressed again S1 again, the shutter just keep moving up toward TOP[0xFF]. The easy way to stop this moving is short pressing S2. When S2 is short pressed, the shutter will move down toward BOTTOM[0x00]. If during this movement S2 is short pressed again S2 again, the shutter just keep moving down toward BOTTOM[0x00]. The easy way to stop this moving is short pressing S1.

When in Two Push Button switch type, S1 or S2 are pressed and not released, and PAN08 receive any control moving command from Z-Wave RF [Ex. BASIC_SET, BINARY_SWITCH_SET, MULTILEVEL_SWITCH_SET, MULTILEVEL_SWITCH_START_LEVEL_CHANGE or MULTILEVEL_SWITCH_STOP_LEVEL_CHANGE or SCENE_ACTIVATION_SET], PAN08 won't do any change in position but report alarm to Group1 [Alarm_Type=1, Alarm_Level =0xFF], this indicate that the S1 or S2 not been release.

ATT.: To avoid misunderstanding that RF command does not work, it is recommended to check the status of S1 and S2.

7.6 | LEVEL REPORT MODE

Mode 1: In 5 seconds period after controlled by a moving command,

it will report the destination level when received request command. Out of the 5 seconds period, it will report the actual level of the shutter when received request command.

Mode 2: Whenever the shutter moves past a 10 percent level, it will auto report the level to Group 1 node.

Z-WAVE COMMAND CLASSES

COMMAND_CLASS_ZWAVEPLUS_INFO
COMMAND_CLASS_VERSION_V2
COMMAND_CLASS_MANUFACTURER_SPECIFIC_V2
COMMAND_CLASS_DEVICE_RESET_LOCALLY
COMMAND_CLASS_ASSOCIATION_V2
COMMAND_CLASS_ASSOCIATION_GRP_INFO
COMMAND_CLASS_POWERLEVEL
COMMAND_CLASS_SWITCH_BINARY
COMMAND_CLASS_BASIC
COMMAND_CLASS_SWITCH_MULTILEVEL_V3
COMMAND_CLASS_CONFIGURATION
COMMAND_CLASS_ALARM
COMMAND_CLASS_METER_V3
COMMAND_CLASS_SCENE_ACTIVATION
COMMAND_CLASS_SCENE_ACTUATOR_CONF
COMMAND_CLASS_FIRMWARE_UPDATE_MD_V2

TROUBLESHOOTING

■ Micromodule is not working and LED is turned off

- Cause of Failure:
 - Micromodule is not connected to the Main power
 - Micromodule is broken

■ Recommendation:

- Check power connections
- Don't open up the Micromodule and send it for repair.

■ The shutter move direction is reverse

- Cause of Failure:

- Wrong connection of NC and NO to the motor

■ Recommendation:

- Swap the NC NO connection

■ Micromodule LED light work fine, but can not control

- Cause of Failure:
 - No association setting
 - Same frequency interference
 - S1 or S2 are pressed in Two Push Button switch type, Micromodule would not accept RF command.

■ Recommendation:

- Carry out association
- Wait for a while to re-try
- Release S1 and S2

Having trouble installing your new product?

Zipato's website contains the latest user documentation and software updates for Zipato products and services:
www.zipato.com

You can also find answers in the Zipato Community at:
community.zipato.com

Zipato Support: support@zipato.com

LIMITED PRODUCT WARRANTY

➔ GENERAL TERMS

Nothing in this Limited Product Warranty affects your statutory rights as a consumer.

The Limited Product Warranty set forth below is given by Tri plus grupa d.o.o. [Europe] (herein referred to as "ZIPATO"). This Limited Product Warranty is only effective upon presentation of the proof

of purchase. Upon further request by ZIPATO, this warranty card has to be presented, too.

EXCEPT AS EXPRESSLY SET FORTH IN THIS LIMITED WARRANTY, ZIPATO MAKES NO OTHER WARRANTIES, EXPRESS OR IMPLIED, INCLUDING ANY IMPLIED WARRANTIES OF MERCHANTABILITY AND FITNESS FOR A PARTICULAR PURPOSE. ZIPATO EXPRESSLY DISCLAIMS ALL WARRANTIES NOT STATED IN THIS LIMITED WARRANTY. ANY IMPLIED WARRANTIES THAT MAY BE IMPOSED BY LAW ARE LIMITED IN DURATION TO THE LIMITED WARRANTY PERIOD. TO THE EXTENT ALLOWED BY LOCAL LAW, THE REMEDIES IN THIS WARRANTY STATEMENT ARE CUSTOMER'S SOLE AND EXCLUSIVE REMEDIES AGAINST ZIPATO. THEY DO NOT, HOWEVER, AFFECT OR RESTRICT THE RIGHTS YOU HAVE AGAINST THE BUSINESS YOU BOUGHT A ZIPATO PRODUCT FROM. IN NO EVENT WILL ZIPATO BE LIABLE FOR LOSS OF DATA OR FOR INDIRECT, SPECIAL, INCIDENTAL, CONSEQUENTIAL (INCLUDING LOST PROFIT OR DATA), OR OTHER DAMAGE, WHETHER BASED IN CONTRACT, TORT, OR OTHERWISE. HOWEVER, NOTHING IN THIS AGREEMENT LIMITS ZIPATO'S LIABILITY TO YOU (I) IN THE EVENT OF DEATH OR PERSONAL INJURY TO THE EXTENT RESULTING FROM ZIPATO'S NEGLIGENCE, OR (II) TO THE EXTENT RESULTING FROM ANY FRAUDULENT MISREPRESENTATION ON THE PART OF ZIPATO, OR (III) TO THE EXTENT ARISING UNDER PART 1 OF THE CONSUMER PROTECTION ACT 1987 OF THE UNITED KINGDOM, SOME STATES OR COUNTRIES DO NOT ALLOW: (1) A DISCLAIMER OF IMPLIED WARRANTIES; (2) A LIMITATION ON HOW LONG AN IMPLIED WARRANTY LASTS OR THE EXCLUSION; OR (3) LIMITATION OF INCIDENTAL OR CONSEQUENTIAL DAMAGES FOR CONSUMER PRODUCTS. IN SUCH STATES OR COUNTRIES, SOME EXCLUSIONS OR LIMITATIONS OF THIS LIMITED WARRANTY MAY NOT APPLY TO YOU. THIS LIMITED WARRANTY GIVES YOU SPECIFIC LEGAL RIGHTS. YOU MAY ALSO HAVE OTHER RIGHTS THAT MAY VARY FROM STATE TO STATE OR FROM COUNTRY TO COUNTRY. YOU ARE ADVISED TO CONSULT APPLICABLE STATE OR COUNTRY LAWS FOR A FULL DETERMINATION OF YOUR RIGHTS. This Limited Product Warranty applies to ZIPATO branded hardware products (collectively referred to as "ZIPATO Hardware Products") sold by ZIPATO (Europe), its European subsidiaries, affiliates, authorized resellers, or country distributors (collectively referred to as "ZIPATO Resellers") with this Limited Product Warranty.

The term "ZIPATO Hardware Product" is limited to the hardware components and all its internal components including firmware. The term "ZIPATO Hardware Product" DOES NOT include any software applications or programs.

📍 GEOGRAPHICAL SCOPE OF THE LIMITED PRODUCT WARRANTY

This Limited Product Warranty is applicable to Hardware Products sold by Zipato Resellers in all countries listed at the beginning of this document under the heading "Countries in which this ZIPATO Limited Product Warranty applies".

The Limited Product Warranty will be honored in any country where ZIPATO or its authorized service providers offer warranty service subject to the terms and conditions set forth in this Limited Product Warranty. However, warranty service availability and response times may vary from country to country and may also be subject to registration requirements.

🔧 LIMITATION OF PRODUCT WARRANTY

ZIPATO warrants that the products described below under normal use are free from material defects in materials and workmanship during the Limited Product Warranty Period set forth below ("Limited Product Warranty Period"), if the product is used and serviced in accordance with the user manual and other documentation provided to the purchaser at the time of purchase (or as amended from time to time).

ZIPATO does not warrant that the products will operate uninterrupted or error-free or that all deficiencies, errors, defects or non-conformities will be corrected.

This warranty shall not apply to problems resulting from: (a) unauthorized alterations or attachments; (b) negligence, abuse or misuse, including failure to operate the product in accordance with specifications or interface requirements; (c) improper

handling; (d) failure of goods or services not obtained from ZIPATO or not subject to a then-effective ZIPATO warranty or maintenance agreement; (e) improper use or storage; or (f) fire, water, acts of God or other catastrophic events. This warranty shall also not apply to any particular product if any ZIPATO serial number has been removed or defaced in any way.

ZIPATO IS NOT RESPONSIBLE FOR DAMAGE THAT OCCURS AS A RESULT OF YOUR FAILURE TO FOLLOW THE INSTRUCTIONS FOR THE ZIPATO HARDWARE PRODUCT.

🕒 LIMITED PRODUCT WARRANTY PERIOD

The Limited Product Warranty Period starts on the date of purchase from ZIPATO. Your dated sales or delivery receipt, showing the date of purchase of the product, is your proof of the purchase date. You may be required to provide proof of purchase as a condition of receiving warranty service. You are entitled to warranty service according to the terms and conditions of this document if a repair to your ZIPATO branded hardware is required within the Limited Product Warranty Period.

[Other than in respect of products for domestic use (in particular those listed in the first and last boxes in the table below), this Limited Product Warranty extends only to the original end user purchaser of this ZIPATO Hardware Product and is not transferable to anyone who obtains ownership of the ZIPATO Hardware Product from the original end-user purchaser.

📅 PRODUCT WARRANTY PERIOD TABLE

PRODUCT TYPE	Micromodule Motor Controller
PRODUCT WARRANTY PERIOD	One (1) year

IMPORTANT

The content of "Product Type" listed above is subject to change; please refer to the www.zipato.com for latest update.

🔧 PERFORMANCE OF THE LIMITED PRODUCT WARRANTY

If a product defect occurs, ZIPATO's sole obligation shall be to repair or replace any defective Zipato Hardware Product free of charge provided it is returned to an Authorized ZIPATO Service Centre during the Limited Warranty Period. Such repair or replacement will be rendered by ZIPATO at an Authorized ZIPATO Service Centre. All component parts or hardware products that are replaced under this Limited Product Warranty become the property of ZIPATO. The replacement part or product takes on the remaining Limited Warranty Period of the replaced part or product. The replacement product need not be new or of an identical make, model or part; ZIPATO may in its discretion replace the defective product (or any part thereof) with any reconditioned equivalent (or superior) product in all material respects to the defective product.

WARRANTOR

Tri plus grupa d.o.o.
Banjavićeva 11
10 000 Zagreb
CROATIA

TEL +385 (0)1 4004 404

FAX +385 (0)1 4004 405

DECLARATION OF CONFORMITY



The manufacturer Tri plus grupa d.o.o declares under our sole responsibility that the product:

Marketing model: Micromodule Motor Controller

Regulatory model: ph-pan08

Trade/Brand name: Zipato

is in conformity with the Low Voltage Directive 2006/95/EC, EMC Directive 2004/108/EC, R&TTE Directive 1995/5/EC and carries the CE marking accordingly.

The following harmonized standards were applied:

R&TTE (1995/5/EC)

EN 300 220-1: V2.4.1

EN 300 220-2: V2.4.1

EMC (2004/108/EC)

EN 301 489-1: V1.9.2

EN 301 489-3: V1.6.1

LVD (2006/95/EC)

EN 60669-2-1:2004 + A1:2009 + A12:2010 used in conjunction with

EN 60669-1:1999 + A1:2002 + A2:2008

Changes or modifications not expressly approved by Tri plus grupa d.o.o. for compliance could void the user's authority to operate the equipment.



THIS DEVICE COMPLIES WITH PART 15 OF THE FCC RULES.

Operation is subject to the following two conditions:

1 | this device may not cause harmful interference, and

2 | this device must accept any interference received, including interference that may cause undesired operation.

NOTE: Changes or modifications not expressly approved by Zipato for compliance could void the user's authority to operate the equipment. This equipment has been tested and found to comply with the limits for a Class B digital device, pursuant to Part 15 of the FCC Rules. These limits are designed to provide reasonable protection against harmful interference in a residential installation. This equipment generates, uses and can radiate radio frequency energy and, if not installed and used in accordance with the instructions, may cause harmful interference to radio communications.

However, there is no guarantee that interference will not occur in a particular installation. If this equipment does cause harmful interference to radio or television reception, which can be determined by turning the equipment off and on, the user is encouraged to try to correct the interference by one or more of the following measures:

- Reorient or relocate the receiving antenna.
- Increase the separation between the equipment and receiver.
- Connect the equipment into an outlet on a circuit different from that to which the receiver is connected.
- Consult the dealer or an experienced radio/TV technician for help.

♻️ DISPOSING AND RECYCLING YOUR PRODUCT

When it reaches end of life, dispose of the product according to your local environmental laws, guidelines and regulations.



This symbol on the product or packaging means that according to local laws and regulations needs to be disposed of separately from household waste. Once this product has reached the end of its life, please take it to a collection point (recycle facilities) designated by your local authorities, some will accept your product for free or simply drop it off at your Zipato re-seller store. By recycling the product and its packaging in this manner you help to conserve the environment and protect human health. At Zipato, we understand and are committed to reducing any impact our operations and products may have on the environment. To minimize this impact Zipato designs and builds its products to be as environmentally friendly as possible, by using recyclable, low toxic materials in both products and packaging.

© COPYRIGHT

© 2015 Tri plus grupa d.o.o. All Rights Reserved.

No part of this manual may be reproduced or transmitted in any form without the expressed, written permission of Tri plus grupa d.o.o.